



Solid Slide Top Series



FEATURES

- ▶ Solid foam insulated sliding lids
- ▶ White powder coated, baked on enamel exterior
- ▶ Aluminum interior
- ▶ Dual heavy duty casters
- ▶ Freezer temperature range 0 F to -18 F
- ▶ Dual drain plugs for easy cleaning
- ▶ Refrigerant CFC-free R-134a
- ▶ Electrical 115V, 60Hz

OPTIONS

- ▶ Thermometer
- ▶ Lock
- ▶ Baskets & Tubholders
- ▶ Custom Graphics
- ▶ Dual Temp Control
- ▶ Light Canopy

SPECIFICATIONS

Model	Baskets (Optional)	External Dimensions W x D x H	Gross Cu Ft	Net Cu Ft	Shipping Weight
SST-30	2	29.5" x 25.8" x 34.8"	6.7	5.3	135
SST-41	4	41.0" x 25.8" x 34.8"	10.4	8.3	166
SST-52	5	51.5" x 25.8" x 34.8"	13.7	11.0	199
SST-61	6	60.5" x 25.8" x 34.8"	16.6	13.4	203
SST-70	7	69.8" x 25.8" x 34.8"	19.5	15.9	213

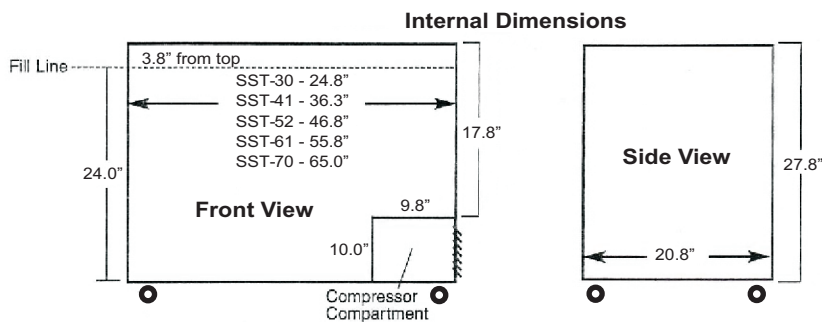

WARRANTY
 18 Months Parts and Labor
 5 Years Compressor (part only)
 Administered by:
 Metalfrio Solutions
 (888) 403-0070 Toll Free

