



## RB19

### REFRIGERATED BARREL

- Barrel Design Cooler
- Stimulates Impulse Purchases
- Low Profile Space Efficient
- Durable Metal Cabinet
- Exterior LED Thermostat Reading
- Easy Lift Glass Lid with Handle
- Eco Friendly R134A Refrigerant
- 2 Coated Interior Wire Product Baskets
- 10' Power Cord
- UL Listed

**IN-HOUSE CUSTOM  
GRAPHICS CAPABILITIES**



# RB19

## Specifications

### Product Capacity (estimated)

- 72-8.3 Ounces
- 42-16 Ounces
- 28-24 Ounces

### Dimensions

Packing: 22"W x 22"D x 34.5"H  
Exterior: 18"W x 33"H  
Net Wt: 51.8 Pounds  
Gross Wt: 59.5 Pounds

### Truck Load

8 Per 40" x 48" Pallet  
28 Pallets  
53' - 224 Units

## Refrigerated Barrel Cooler

- Barrel Design Cooler
- Stimulates Impulse Purchases
- Low Profile Space Efficient
- Durable Metal Cabinet
- Durable Baked-on Paint Finish
- Factory Engineered Refrigeration System
- Factory Set Thermostat
- Eco Friendly R134A Refrigerant
- Exterior LED Thermostat Reading
- Exterior On/Off Switch
- 10' Power Cord
- Easy Lift Glass Lid with Handle
- 2 Coated Interior Wire Product Baskets (for easy product rotation)
- 2" Casters

## Dimensions 18" x 33" H

**2 Baskets  
for  
Easy Product  
Rotation**

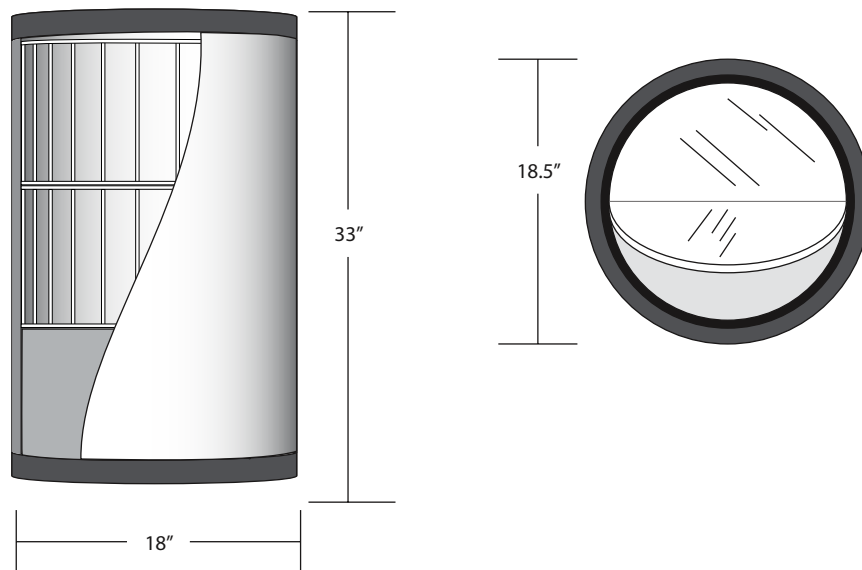

**WARRANTY:** One Year Parts | 90 Days Labor **SPARE PARTS:** Inventoried

