

# PureWaterCooler™

by VERTEX

## PWC 1500



## New 2-temp cooler with Modern Look

*Sleek, upscale bottle-less cooler with filtration provides great tasting hot and cold water from your tap. Contemporary styling fits with today's modern offices. Eliminates the hassle of 5-gallon bottles.*

### Features

- Two temperature system  
Cold: 37-50° F, Adjustable • Hot: 185° F, Autocontrol  
LED indicator for Hot and Cold water on the front panel
- Individual on/off control switches for cold and hot water on rear panel
- Completely sealed stainless steel cold reservoir and hot tank
- Convenient, enclosed, no-drip dispensing faucets
- Built-in filtration system is easily accessed for replacement  
Available with Reverse Osmosis filtration system  
Or Standard Dual-Cartridge filtration system
- Available with ultraviolet sterilizer

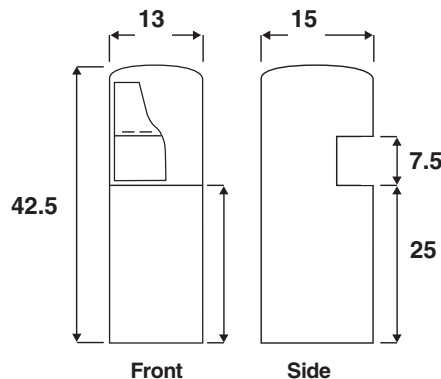

Front Side

Dimensions (inches)



Silver and Black option.

### Specifications

Shipping Weight: 60 lb.  
Dimension: 13"W x 15"D x 42.5"H  
Cold tank volume 1 gal  
Hot tank volume .5 gal  
Cooling Rate: 1.5 gal/hr 37-50 °F  
Heating Rate: 1.3 gal/hr 185 °F  
Voltage: 100-120 volts, 50/60 hz  
Power Required: 600w

Meets Energy Star Requirements



### Filter System

Standard Filter **1500F**  
**Stage 1:** 5 micron Sediment  
**Stage 2:** 10 micron Activated Carbon  
Reverse Osmosis Filter **1500R**  
Above 2 stages plus  
**Stage 3:** 50-GPD RO Membrane  
Automatic tank full control  
Fully assembled  
- connection hardware included

### ORDERING INFORMATION

2-Temp Model with Reverse Osmosis	<b>PWC-1500R</b>
2-Temp Model with Standard Filtration	<b>PWC-1500F</b>
Silver and Black Cabinet	add <b>/S</b>
2-Temp Dispenser with UV stage	add <b>/UV</b>
Leak detector option	<b>LC-8021</b>
Cup holder	<b>CPH-1207</b>
Replacement Filters	
Sediment	<b>IFA-4035</b>
GAC Carbon	<b>IFA-4034</b>
RO membrane, 50 GPD	<b>MA-4203</b>

Authorized Dealer

